

hydraulic valve

urinal flush control valve



reduces water consumption
and washroom odours

The **hydraulic valve** is an automatic urinal flush control valve. The valve uses a simple patented mechanism which prevents water waste by ensuring that the auto-flush cistern is only filled, and can only flush, when the washroom is used.

- Automatic urinal flush control
- Unique patented hydraulic mechanism – no electrical supply or batteries required
- Industry leader with half a million already installed
- ‘Fit and Forget’ quality and reliability
- Hygiene flush option for periods of non-use
- Ensures compliance with the Water Regulations
- On DEFRA’s ECA Water Technology List; purchase and installation are tax deductible

how it works

The Cistermiser **hydraulic valve** is installed on the supply pipe to the urinal cistern. The valve is activated by short-term pressure drops created by use of taps or WCs on the same supply.

The valve is normally closed; when it is activated it opens and water passes to the urinal cistern until the pressures on both sides of the valve are equalised. When the cistern is full the auto-siphon will flush.



product description

- The valve is installed on the supply pipe to the urinal cistern.
- The installer or user can adjust the time the valve remains open and therefore how long the cistern takes to fill and how much water is used. When the washroom is not being used the water supply pressure remains constant and the valve remains closed preventing water passing into the cistern.
- The cistern can therefore only flush during periods when the washroom is in use, eliminating unnecessary water consumption and cost.

hygiene cycle

In buildings where the washrooms are vacant for long periods, a hygiene cycle attachment is available to ensure a regular flush every 12 hours to prevent washroom odours.

The bypass screw should be set to permit a slow drip into the cistern to initiate a flush approximately every 12 hours. For correct operation it is essential that the siphon of the auto flushing cistern does not leak.

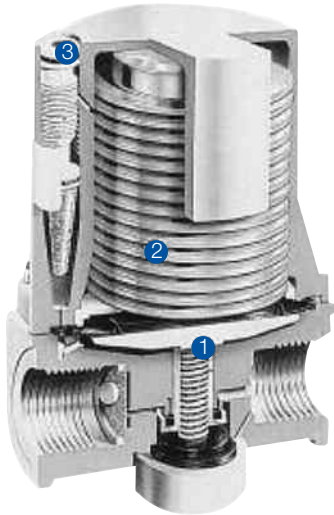



The Cistermiser **hydraulic valve** consists of three main elements as shown opposite.

- 1 Diaphragm operated valve which, when opened, allows water to pass to the urinal cistern.
- 2 Hydraulic accumulator which, if fully charged, will maintain an equal supply-pressure on both sides of the diaphragm. When pressure on the inlet side is reduced, as other services are used, the pressure imbalance causes the valve (1) to open.
- 3 Adjuster (restrictor) screw which can be set during installation to determine the volume of water discharged into the cistern at each operation by altering the duration of the 'open' period.

choosing the right valve for your application

Three models make up the range of **hydraulic valves**, each suited to a different range of water supply pressure. This table will help to specify the right model for your application.

Colour coded packaging	Model	Supply	Operating sensitivity
	Standard Valve STD 6073/A ...with Hygiene Flush STD 6073/A/HF	Mains water or tank-fed systems above 5m head	15% of supply pressure
	Low Pressure Valve LP 6074/A ...with Hygiene Flush LP 6074/A/HF	Tank-fed systems, 3m to 5m head	20% of supply pressure
	High Sensitivity Low Pressure Valve HSLP 6075	Tank-fed systems, 0.5m to 3m head	20% of supply pressure

Note: The user can control the amount of water allowed to pass through the valve each time it is activated; most users choose a range between 0.5 and 10 litres per flush.

specification wording

The mechanical contractor shall supply and install a urinal flushing device of the 'Cistermiser Hydraulic Valve' type on the supply pipe to the urinal cistern, as shown on the drawing.

The flushing control device shall be a mechanical, hydraulic device operated by changes in system pressure due to demand on connected water services within the washroom.

standard valve

The flushing control device shall be suitable for supply system pressures of between 0.5 and 6.0 bar (typically either mains water or tank-fed systems above 5m head).

low pressure valve

The flushing control device shall be suitable for supply system pressures of between 0.3 and 0.5 bar (typically tank-fed systems between 3m and 5m head).

high sensitivity low pressure valve

The flushing control device shall be suitable for supply system pressures of between 0.05 and 0.3 bar (typically tank-fed systems between 0.5m and 3m head).

The above flushing control device shall be as manufactured by: Cistermiser Limited
Unit 1, Woodley Park Estate, 59 – 69 Reading Road,
Woodley, Reading, RG5 3AN Td: 0118 969 1611

product codes

Standard Hydraulic Valve:	STD 6073/A
Standard Hydraulic Valve with Hygiene Flush	STD 6073/A/HF
Low Pressure Hydraulic Valve:	LP 6074/A
Low Pressure Hydraulic Valve with Hygiene Flush	LP 6074/A/HF
High Sensitivity Low Pressure Valve	HSLP 6075