

MIQ MINERAL INSULATED HEATING CABLE INSTALLATION INSTRUCTIONS

MIQ CATALOGUE REF. NO.

Example: D / MIQ-50E3H-2S / 200 / 1404 / 120 / 4 / 12 / 6

Design (A,B,D,E) D

Cable Reference MIQ-50E3H-2S

Length (Feet or Meters)¹ 200

Watts 1404

Volts 120

Cold Lead Length (Feet or Meters)¹ 4

Cold Lead AWG 12

Cold Lead Voltage Rating 6

1. If the unit of measurement is omitted, the imperial measurement of feet will be assumed. Metric lengths are followed by the letter "m".

HEATER SET TYPES

A



B

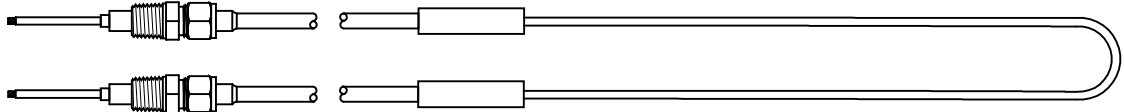

D

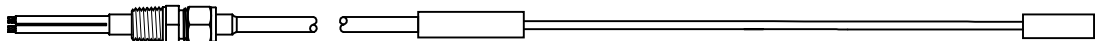

E

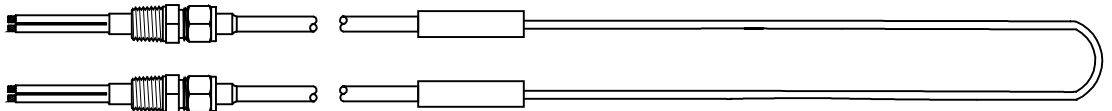

WARNING:

See rule 62-300 of the CE CODE, PART I for ground fault protection requirements.

THERMON HEAT TRACING SERVICES - Strongly recommends the use of ground fault protection on all heat tracing circuits, including cables with metal braids or sheaths, even when not required by code.

WARNING:

EXPLOSION HAZARD - Do not install in environments having gas or vapour-air mixtures with an ignition temperature lower than that indicated by the CE Code or temperature marking on the electric heating cable set.

See Appendix B (Rule 18-054) of the CE Code, Part I for specific information on ignition temperatures.



02.04

THERMON HEAT TRACING SERVICES
333 - 28 STREET N.E.
CALGARY, ALBERTA T2A 7P4
(403)273-5558 FAX. (403)273-5695

INSTALLATION OF MIQ
MINERAL INSULATED HEATING CABLE

FORM 5001-01C

REV. D

SHEET 1 OF 8

INSTALLATION PROCEDURE FOR MIQ HEATING CABLE

I. UPON RECEIVING HEATING CABLE:

A. Check the cable set to make sure the proper type has been received.

HEATING CABLE IDENTIFICATION CHART

600V RATED CABLE				300V RATED CABLE	
ONE (1) CONDUCTOR	Ohms/ft. @20 ° C	TWO (2) CONDUCTOR	Ohms/ft. @20 ° C	TWO (2) CONDUCTOR	Ohms/ft. @20 ° C
MIQ-20E1H-1S	2.00	MIQ-11E0H-2S	11.00	MIQ-11E0L-2S	11.00
MIQ-16E1H-1S	1.60	MIQ-90E1H-2S	9.00	MIQ-90E1L-2S	9.00
MIQ-13E1H-1S	1.30	MIQ-60E1H-2S	6.00	MIQ-75E1L-2S	7.50
MIQ-10E1H-1S	1.00	MIQ-40E1H-2S	4.00	MIQ-60E1L-2S	6.00
MIQ-85E2H-1S	0.85	MIQ-20E1H-2S	2.00	MIQ-50E1L-2S	5.00
MIQ-70E2H-1S	0.70	MIQ-10E1H-2S	1.00	MIQ-40E1L-2S	4.00
MIQ-50E2H-1S	0.50	MIQ-70E2H-2S	0.70	MIQ-32E1L-2S	3.20
MIQ-38E2H-1S	0.38	MIQ-50E2H-2S	0.50	MIQ-27E1L-2S	2.70
MIQ-30E2H-1S	0.30	MIQ-30E2H-2S	0.30	MIQ-25E1L-2S	2.50
MIQ-25E2H-1S	0.25	MIQ-20E2H-2S	0.20	MIQ-20E1L-2S	2.00
MIQ-20E2H-1S	0.20	MIQ-15E2H-2S	0.15	MIQ-17E1L-2S	1.70
MIQ-17E2H-1S	0.17	MIQ-10E2H-2S	0.10	MIQ-14E1L-2S	1.40
MIQ-15E2H-1S	0.15	MIQ-70E3H-2S	0.07	MIQ-10E1L-2S	1.00
MIQ-10E2H-1S	0.10	MIQ-50E3H-2S	0.05	MIQ-70E2L-2S	0.70
MIQ-80E3H-1S	0.080	MIQ-40E3H-2S	0.04	MIQ-50E2L-2S	0.50
MIQ-70E3H-1S	0.070	MIQ-30E3H-2S	0.03	MIQ-30E2L-2S	0.30
MIQ-60E3H-1S	0.060	MIQ-20E3H-2S	0.020	MIQ-25E2L-2S	0.25
MIQ-40E3H-1S	0.040	MIQ-16E3H-2S	0.016	MIQ-20E2L-2S	0.20
MIQ-30E3H-1S	0.030	MIQ-13E3H-2S	0.013	MIQ-15E2L-2S	0.15
MIQ-20E3H-1S	0.020	MIQ-10E3H-2S	0.0104	MIQ-10E2L-2S	0.10
MIQ-10E3H-1S	0.010			MIQ-70E3L-2S	0.070
MIQ-65E4H-1S	0.00651			MIQ-50E3L-2S	0.050
MIQ-40E4H-1S	0.00409				
MIQ-25E4H-1S	0.00258				
MIQ-16E4H-1S	0.00162				

CAUTION: DO NOT connect power to heating cable while it is in shipping carton or coiled off pipe.

B. Visually inspect cable for any damage incurred during shipment. Perform insulation resistance test as described in installation note 2. Measure DC resistance and compare to value on fab sheet provided with set.

C. Store in dry area.

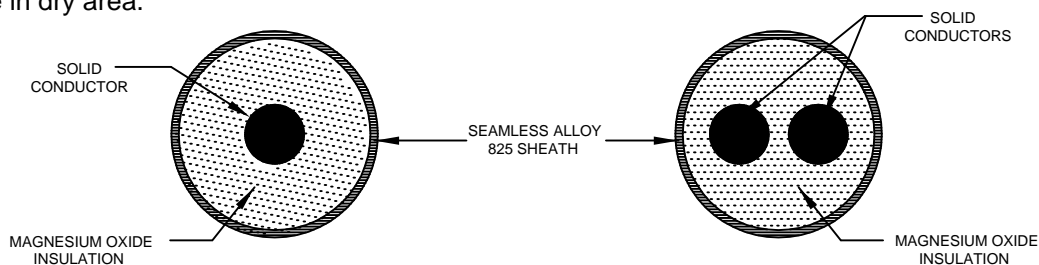

THERMON HEAT TRACING SERVICES
 333 - 28 STREET N.E.
 CALGARY, ALBERTA T2A 7P4
 (403)273-5558 FAX. (403)273-5695

**INSTALLATION OF MIQ
 MINERAL INSULATED HEATING CABLE**

II. BEFORE INSTALLING HEATING CABLE:

- A. Make sure all piping and equipment to be traced is completely installed and tested in accordance with applicable codes.
- B. Pipes and equipment surface should be reasonably clean. Any loose scale, oil, or rust should be removed.
- C. Pipe heating cable must be installed in accordance with the Canadian Electric Code. Installation shall also be in accordance with the standards as outlined in IEEE Standard 515. Review these documents as well as any applicable local codes and standards prior to beginning the installation.
- D. Refer to the heat tracing isometric for power point location, equipment allowances, etc. Confirm if any sets are to be connected in series.

III. INSTALLATION OF HEATING CABLE:

TYPICAL INSTALLATION

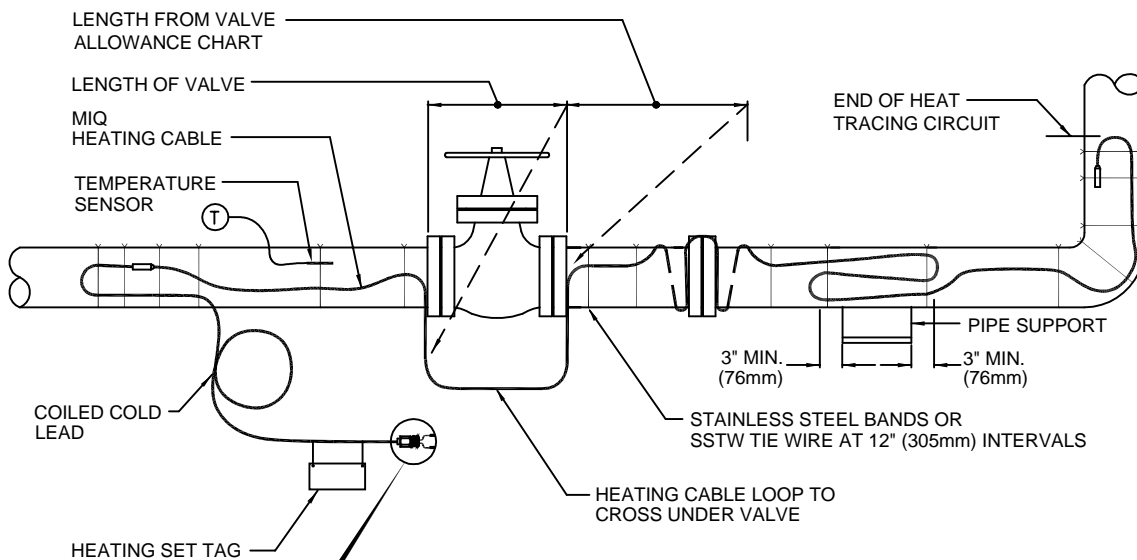

RECOMMENDED ORIENTATION OF HEAT TRACING

(WHEN 3 OR MORE HEATING CABLES ARE INSTALLED EQUALLY SPACE AROUND PIPE.)

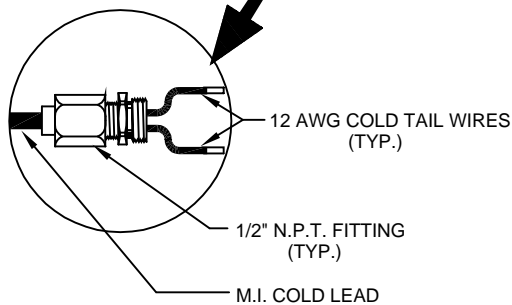
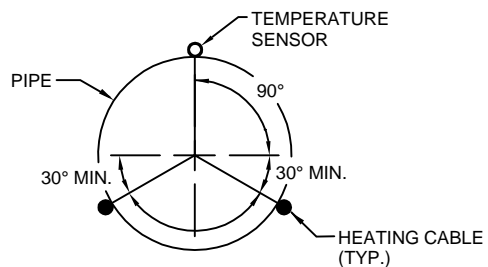

02.04

THERMON HEAT TRACING SERVICES
 333 - 28 STREET N.E.
 CALGARY, ALBERTA T2A 7P4
 (403)273-5558 FAX. (403)273-5695

INSTALLATION OF MIQ
 MINERAL INSULATED HEATING CABLE

FORM 5001-03C REV. D SHEET 3 OF 8

III .INSTALLATION OF HEATING CABLE (cont'd)

- A. Permanently install heating cable on pipe, valves and equipment by starting with the cold lead section (power end) and working towards the end section (hot end).
- B. Install cable with slight "wave" as shown in step 3. Heating cable minimum bend radius is 6x cable O.D.
- C. Secure the heating cable to the pipe using SSTW tie wire or stainless steel banding straps at 12" (305 mm) intervals. Use only thermon approved banding materials. Do not overtighten banding or tie wire.
- D. For extreme temperature exposure see detail on sheet #8.
- E. Route MI cable set cold lead(s) into junction box hub(s). Slowly tighten gland connector with set of wrenches until ferrule begins to make positive contact with cold lead sleeve and cold lead cannot be moved by hand. Then tighten fitting 1/8 additional turn.
- F. Any excess cable must be distributed evenly along pipe and equipment.

TYPICAL ARRANGEMENT

STEP 1

LAY HEATING CABLE ALONG SIDE OF PIPE AND FIX HOT TO COLD JUNCTION. BAND JUNCTION AT 6"(152mm) DISTANCE ON BOTH SIDES.

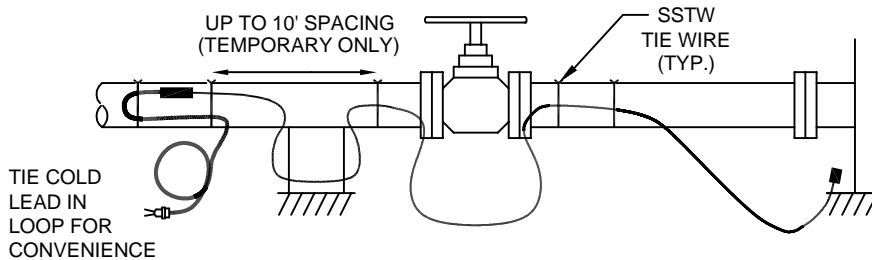
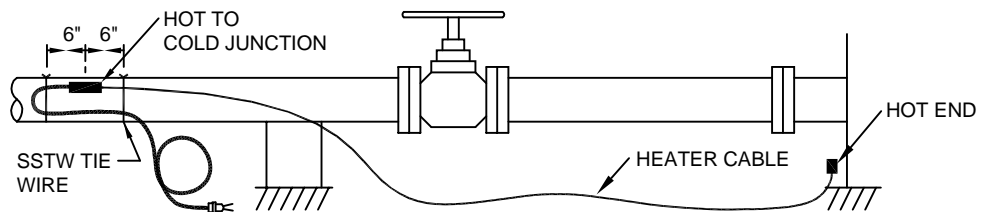

STEP 2

TEMPORARILY TIE CABLE TO PIPE LEAVING MEASURED ALLOWANCES FOR HEAT SINKS.

STEP 3

ADJUST CABLE WHERE NECESSARY AND START TO SECURE WITH SSTW TIE WIRES AND FORM CABLE AROUND HEAT SINKS.

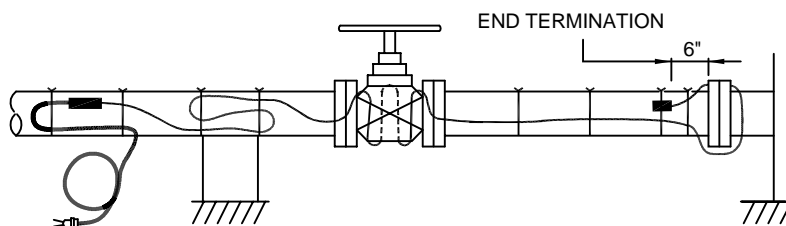
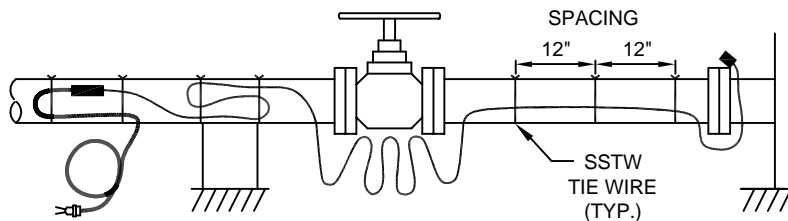

STEP 4

COMPLETE SECURING OF CABLE WITH SSTW TIE WIRES TO END OF PIPE.



02.04

THERMON HEAT TRACING SERVICES
333 - 28 STREET N.E.
CALGARY, ALBERTA T2A 7P4
(403)273-5558 FAX. (403)273-5695

INSTALLATION OF MIQ
MINERAL INSULATED HEATING CABLE

FORM 5001-06C

REV. C

SHEET 4 OF 8

III . INSTALLATION OF HEATING CABLE (cont'd)

HEATING CABLE ALLOWANCE FOR VALVES/FLANGES

	NOMINAL PIPE SIZE (INCH)																	
	1/2"	3/4"	1"	1 1/2"	2"	2 1/2"	3"	4"	6"	8"	10"	12"	14"	16"	18"	20"	24"	30"
SCREWED OR WELDED VALVE	6"	9"	1'-0"	1'-6"	2'-0"	2'-6"	2'-6"	4'-0"	7'-0"	9'-6"	12'-6"	15'-0"	18'-0"	21'-6"	25'-6"	28'-6"	34'-0"	40'-0"
FLANGED VALVE	1'-0"	1'-6"	2'-0"	2'-6"	2'-6"	3'-0"	3'-6"	5'-0"	8'-0"	11'-0"	14'-0"	16'-6"	19'-6"	23'-0"	27'-0"	30'-0"	36'-0"	42'-0"
BUTTERFLY VALVE	0"	0"	1'-0"	1'-6"	2'-0"	2'-6"	2'-6"	3'-0"	3'-6"	4'-0"	4'-0"	5'-0"	5'-6"	6'-0"	6'-6"	7'-0"	8'-0"	10'-0"
FLANGES	4"	4'	4"	5"	5"	5"	5"	6"	6"	6"	7"	8"	9"	10"	10"	11"	1'-0"	1'-7"

	NOMINAL PIPE SIZE (MM)																					
	10	15	20	25	30	40	50	65	80	100	125	150	200	250	300	350	400	450	500	600	700	800
SCREWED OR WELDED VALVE	0.15	0.20	0.30	0.35	0.40	0.50	0.60	0.75	0.95	1.2	1.6	2.0	2.8	3.7	4.6	5.5	6.5	7.5	8.5	10.2	11.6	12.6
FLANGED VALVE	0.35	0.40	0.45	0.55	0.65	0.75	0.85	1.05	1.25	1.6	1.9	2.3	3.2	4.1	5.0	6.0	7.0	8.0	9.0	10.8	12.2	13.3
BUTTERFLY VALVE	0	0	0.25	0.30	0.35	0.45	0.50	0.60	0.70	0.80	0.95	1.05	1.2	1.4	1.6	1.8	2.0	2.2	2.4	2.6	2.9	3.2
FLANGES	0.22	0.24	0.25	0.28			0.36		0.48	0.58	0.64	0.71	0.86	1.0	1.2	1.3	1.5	1.6	1.75	2.0		

ALL ALLOWANCES IN METERS

- NOTES: (1) SCREWED, WELDED AND FLANGED VALVES INCLUDE WEDGE PLUG, GLOBE DIAPHRAGM GATE, MULTI-PORT CONTROL AND GLAND.
 (2) IF MULTIPLE TRACERS ARE USED, VALVE ALLOWANCE IS FOR ONE TRACER IF SPACE ALLOWS. VALVE ALLOWANCE TO BE ALTERNATED AMONG TRACERS FOR MULTIPLE VALVES IN A HEAT TRACE CIRCUIT.
 (3) ABOVE ALLOWANCES FOR 150 POUND VALVES. MORE CABLE IS REQUIRED FOR HIGHER RATINGS.
 (4) REFER TO HEAT TRACE ISOMETRIC DRAWING FOR ACTUAL ALLOWANCES.

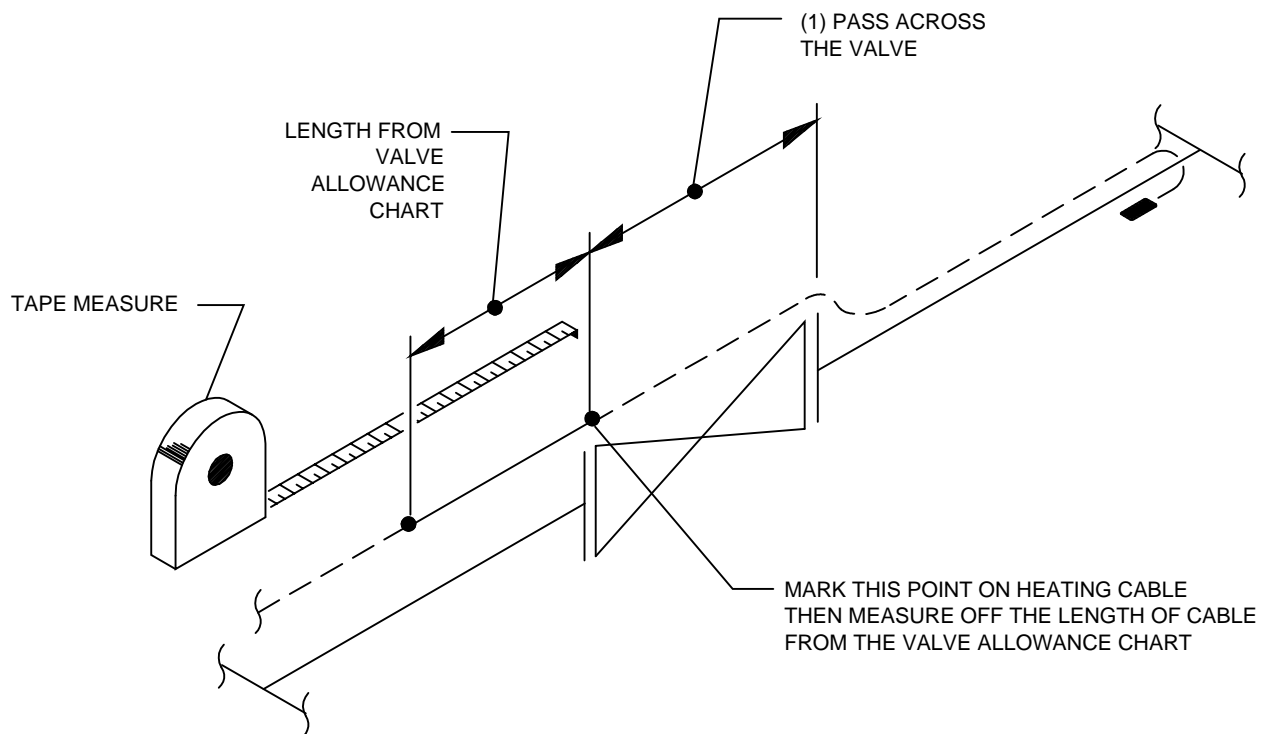

THERMON HEAT TRACING SERVICES
 333 - 28 STREET N.E.
 CALGARY, ALBERTA T2A 7P4
 (403)273-5558 FAX. (403)273-5695

INSTALLATION OF MIQ
 MINERAL INSULATED HEATING CABLE

III . INSTALLATION OF HEATING CABLE (cont'd)

ELBOWS

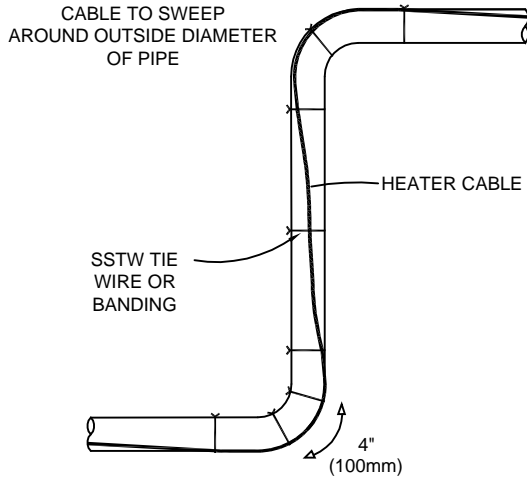

VALVES

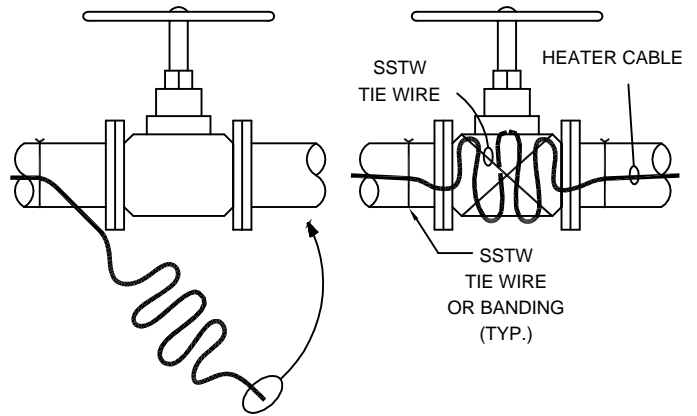

FLANGES

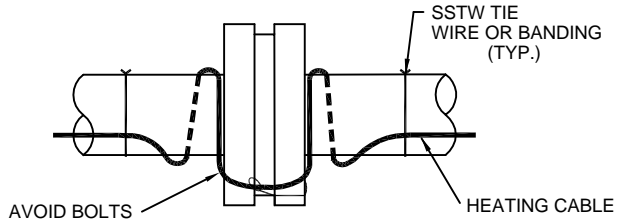

NOTE: ON SMALL FLANGES AND JOINTS, TO AVOID THE RISK OF THE CABLE BECOMING EMBEDDED IN INSULATION, ONE OF THREE METHODS CAN BE ADOPTED.

- (A) WRAP CABLE AND FLANGE WITH ALUMINIUM FOIL TAPE AND SECURE WITH TIE WIRE.
- (B) USE THIN, NON RUSTING METAL BRIDGING PIECES ACROSS FLANGE TO SUPPORT CABLE.
- (C) USE THERMON HEAT TRANSFER CEMENT TO FILL GAP BETWEEN CABLE AND FLANGE.

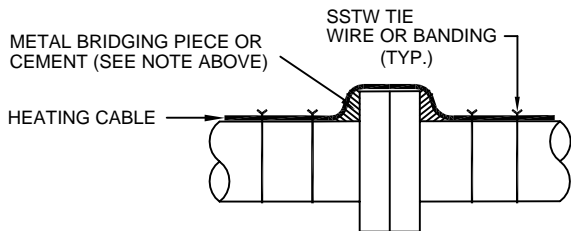

NOTE:

FOR SMALL VALVES (ie: LESS THAN 2") IT MAY IMPRACTICAL TO INSTALL THE CORRECT CABLE ALLOWANCE ON THE VALVE BODY ITSELF. IT CAN BE INSTALLED IN A UNIFORM MANNER ACROSS MANNER ACROSS THE VALVE AND EITHER SIDE OF THE PIPE AS SHOWN BELOW.

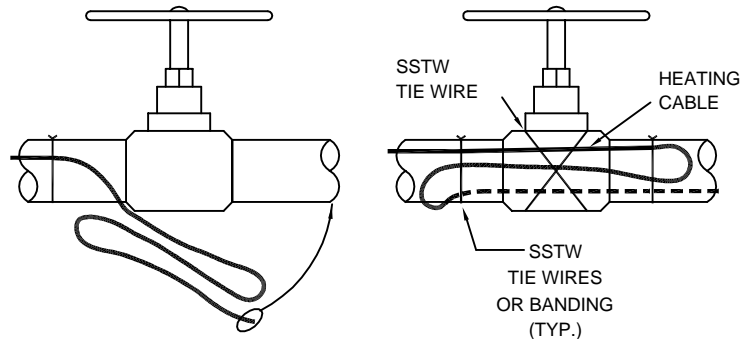

02.04

THERMON HEAT TRACING SERVICES
 333 - 28 STREET N.E.
 CALGARY, ALBERTA T2A 7P4
 (403)273-5558 FAX. (403)273-5695

INSTALLATION OF MIQ
 MINERAL INSULATED HEATING CABLE

FORM 5001-07C

REV. D

SHEET 6 OF 8

III. INSTALLATION OF HEATING CABLE (Cont'd)

PUMPS

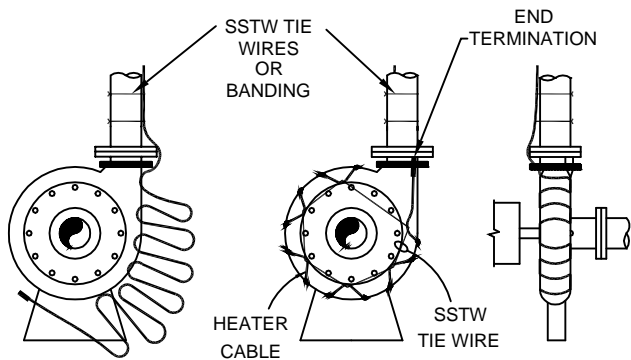

SHOES

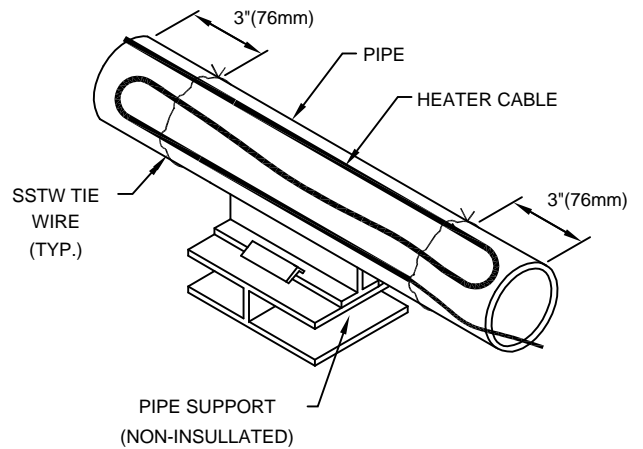

HANGER

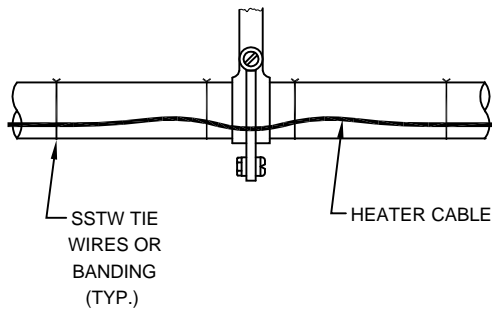

EXTREME TEMPERATURE EXPOSURE INSTALLATION

HOT END TERMINATION FITTING (LIFTED OFF PIPE AND INTO THE INSULATION & SUPPORTED WITH A BLOCK OF RIGID INSULATION).

HOT-COLD LEAD TERMINATION FITTING (LIFTED OFF PIPE AND INTO THE INSULATION & SUPPORTED WITH A BLOCK OF RIGID INSULATION).

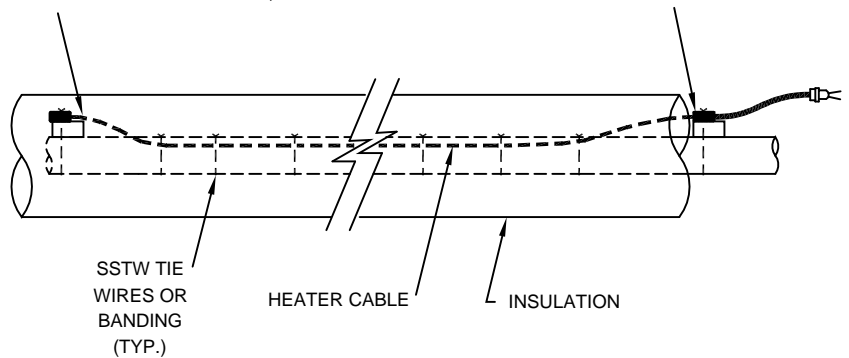

02.04

THERMON HEAT TRACING SERVICES
333 - 28 STREET N.E.
CALGARY, ALBERTA T2A 7P4
(403)273-5558 FAX. (403)273-5695

INSTALLATION OF MIQ
MINERAL INSULATED HEATING CABLE

FORM 5001-09C

REV. C

SHEET 7 OF 8

III . INSTALLATION OF HEATING CABLE (cont'd)

INSTALLATION NOTES

1. Heating cable shall not touch, cross over, or overlap itself.
2. Test insulation resistance of heating cable set when received, when installed with pipe uninsulated, and after thermal insulation has been installed. Using a 500 Vdc megohmmeter, the minimum acceptable reading is 5 megohms between conductor and metallic sheath. Use of a 1000 Vdc megohmmeter is recommended. Perform test with set de-energized and all circuit neutrals isolated from ground. Record readings.
3. Metal structures or materials used for the support of or on which cables or sets are installed, are to be grounded in accordance with CSA standard C221.1, Section 10.
4. Minimum installation temperature is -30° C.
5. Do not alter heating cable set length.
6. Do not remove metal tags from heating cable set.
7. Thermostat or solid state temperature control device must be used.
8. Heating cable must not be embedded in the thermal insulation.
9. Heating cable set shall be spaced at least 13 mm (1/2") from any combustible surface.
10. MI Cable Set cold lead ends must be kept dry before, during and after installation.
11. Do not damage cable by repeatedly bending and straightening at same location.
12. Do not bend cable less than 6" away from hot-to-cold joint, splice, or end termination.
13. Minimum spacing between cables is 1" when installing multiple passes or loops.
14. The metal covering shall not be used as the bonding-to-ground means. Alternate means of protection shall be provided per C.E. Code Part I. The metal covering on this set and metal structures or materials used for the support of this set shall be grounded.
15. Provisions must be made to protect MIQ cable from welding slag, grinders, etc.
16. Keep lids on all power and splice junction boxes.
17. Refer to Thermon Form TMP0006-0901 for information on electrical safety precautions for electrical heat tracing.
18. At a tee branch in a pipeline, particularly if the branch pipe is smaller than the main pipe, double tracing the smaller pipe with the main heating unit may cause unbalanced pipe temperature. Use caution, check schedules to see if permissible.

Determine Heat Loss

There are several ways to determine the heat loss for pipes under a given set of design conditions:

- Heat loss calculations such as those detailed in IEEE Std.515-1997 (IEEE Standard for the Testing, Design, Installation, and Maintenance of Electrical Resistance Heat Tracing for Industrial Applications).
- Computer-aided design programs that allow the user to input detailed information specific to an application. (Thermon's CompuTrace® design and selection program provides this and more based on the formulas presented in IEEE Std. 515-1997).
- Heat loss charts based on selected pipe diameters, temperature differentials and insulation materials.
- Please contact Thermon for additional information on pipe heat loss.



02.04

THERMON HEAT TRACING SERVICES
333 - 28 STREET N.E.
CALGARY, ALBERTA T2A 7P4
(403)273-5558 FAX. (403)273-5695

INSTALLATION OF MIQ
MINERAL INSULATED HEATING CABLE

FORM 5001-011C

REV. C

SHEET 8 OF 8