

ST-IAM - Sensor Transmitter Integrated Area Monitor

Installation & Operation*

Content	Page
1- External Connections to the ST-IAM	2
2- Main PCB Connections	2
3- Location Instructions	2
4. Typical settings	3
5- Operating Instructions	3
6- Test/Function Instruction	3
7- Remote sensor head installation	3
8- Annual Test	4
9- Troubleshooting	4
10- Connections to the ST-MON panel 8 or 16 Models a. Internal Connection Terminals	4
11- Communication interface – RS485 a. Sensor addresses	4
12- Connections to repeater (if more than 31 ST-IAM sensors in the system)	4
13- Agree Selectable functions with end users	5
14- Mounting Diagrams	5



*Technician use only

This unit must be installed by a suitably qualified technician who will install this unit in accordance with these instructions and the standards set down in their particular industry/country. Suitably qualified operators of the unit should be aware of the regulations and standards set down by their industry/country for the operation of this unit. These notes are only intended as a guide and the manufacturer bears no responsibility for the installation or operation of this unit.

Failure to install and operate the unit in accordance with these instructions and with industry guidelines may cause serious injury including death and the manufacturer will not be held responsible in this regard.

08 ASH (1)



www.heatracing.co.uk
Thorne and Derrick UK
Tel 0044 191 490 1547 Fax 0044 191 477 5371
Tel 0044 117 977 4647 Fax 0044 117 9775582
www.thorneandderrick.co.uk



1- External Connections to the ST-IAM

All external connections are made to the motherboard through a cable gland. A cable tie should be fitted within 20mm of the cable gland inside the enclosure. The connectors are plug and socket type, and will accept wire of 0.5-1.5mm sq. (Keep cable runs to a minimum)

Diagram 1. ST-IAM connections

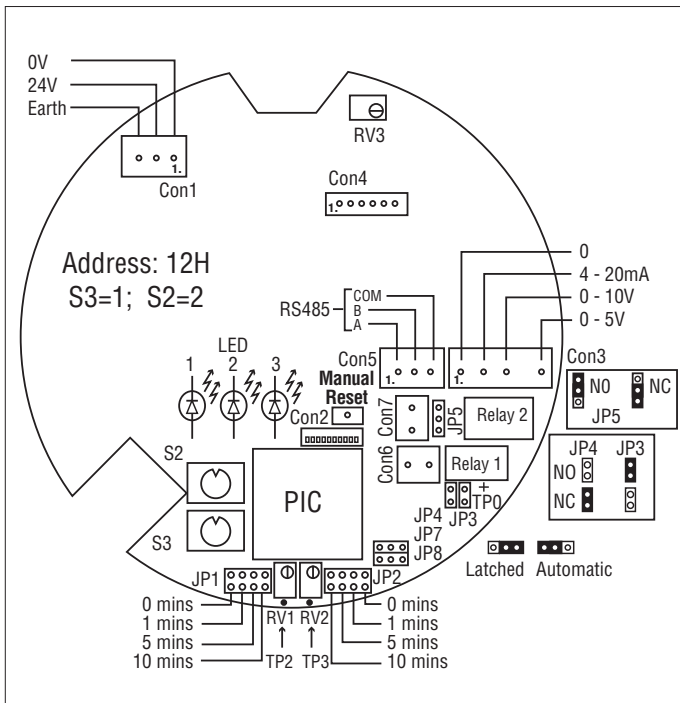

2- ST-IAM Main PCB Connections

We suggest Beldon 8761, 22awg single pair shielded, Beldon 8450 22awg individually shielded pairs or alternatively an alarm type cable of 7/0.2mm, 22awg.

- CON 1:** Power Supply input and consumption (see table 1)
Power on indicated by LED1 Green. LED's 2+3, Red and Yellow flash for 2 seconds (software check).
Supply voltages to be either 12 to 24 Vac or 12 to 30Vdc. (see table 1)
Power consumption is 4 watts max at 12v. Except for CO2 Low Temperature model (see table 1)
Sensor will normalize in minutes up to 24 hours.



Earth connection must be made when using the ST-IAM vented metal enclosure or Exd enclosure. The safety of this equipment is dependent on the integrity of the power supply and the earthing of the ST-IAM 2 enclosure.

- CON 2:** Display Connection (Optional)

- CON 3:** Analogue Output
Pin 1: 0V
Pin 2: 4-20mA. Load resistance < 400Ω
Pin 3: 0-10V. Load resistance > 10KΩ
Pin 4: 0-5V. Load resistance > 10KΩ

When connecting the 4-20mA to the ST-MON Control Panel Pin 2, CON 3 is connected to a location between 1 to 16 on the ST-MON connector strip. Pin 1 (0 V) CON 3 is connected to the nearest C terminal, which is common for each 4-signal connector positions.

- CON 4:** Daughter board plug-in connection (installed in Factory)

- CON 5:** RS485 Interface
Pin 1 = A (A connects to A of ST-MON Panel, B to B, etc) (See Diagram 2)
Pin 2 = B

Pin 3 = Common (connect to RS485 cable screen/shield)

Setting Addresses see table 2

You need a minimum 2 core with a common drain wire (screen) communications cable

- CON 6:** Relay 1 contacts (1Amp 24V AC/DC)
Low-level alarm. Indicated by LED3, Yellow.
Normally closed (as shown on Diagram 1).
Normally open (as shown on Diagram 1). **(Default)**
Latching set by JP8 (see diagram 1) **(Default Automatic)**.
Alarm Threshold level set by RV1 and can be set by putting a meter between TP0 (negative) and TP2 (positive) and adjusting RV1 (scale is 0 to 5V e.g. 2.5V is 50% of calibrated range).
Delayed response time set by JP1 link (see diagram 1) **(Default 0 minutes)**
- CON 7:** Relay 2 contacts (1Amp 24V AC/DC)
High-level alarm. Indicated by LED2, Red.
Normally closed/open **(Default)** set by JP5 (as shown on diagram 1).
Latching set by JP7 (see diagram 1) **(Default Automatic)**.
Alarm threshold level set by RV2 and can be set by putting a meter between TP0 (negative) and TP3 (positive) and adjusting RV2 (see CON 6 above).
Delayed response time is set by JP2 link (See Diagram 1) **(Default 0 minutes)**.

Alarm Thresholds: Check rating plate on the side of the ST-IAM for alarm relay settings.

3- ST-IAM Location Instructions

Location of Sensors

Sensors must be located within the appropriate wire lengths from the central control unit (if used).

In all cases the sensor supplied is designed for maximum sensitivity to a particular gas.

However, in certain circumstances false alarms may be caused by the occasional presence of sufficiently high concentrations of other gaseous impurities. If such a situation is likely to arise installers should check with our Technical Department so that sensor (s) of suitable cross sensitivity can be supplied. Examples of situations where such abnormalities may arise include.

- Plant room maintenance activity involving solvent or paint fumes or refrigerant leaks.
- Plant rooms in fruit ripening/storage facilities because of accidental gas migration (bananas - ethylene, apples - carbon dioxide)
- Heavy localised exhaust fumes (carbon monoxide, dioxide, propane) from engine driven forklifts in confined spaces or close to sensors.

A response delay may be selected to minimise any problems that might arise.

Machinery rooms

There is NO ABSOLUTE RULE in determining the number of sensors and their location. However a number of simple guidelines will help to make a decision. Sensors monitor a point as opposed to an area. If the gas leak does not reach the sensor then no alarm will be raised. Therefore, it is extremely important to carefully select the sensor location. Also consider ease of access for maintenance.

The size and nature of the site will help to decide which method is the most appropriate to use. Locations requiring the most protection in a machinery or plant room would be around compressors, pressurised storage vessels, refrigerant cylinders or storage rooms or pipelines. Most vulnerable are valves, gauges, flanges, joints (brazed or mechanical), filling or draining connections etc

When mechanical or natural ventilation is present mount a sensor in the airflow. In machinery rooms where there is no discernable or strong airflow then options are:

- Point Detection, where sensors are located as near as possible to the most likely sources of leakage, such as the compressor, expansion valves, mechanical joints or cable duct trenches, and,
- Perimeter Detection, where sensors completely surround the area or equipment.
- With heavier than air gases such as halocarbon and hydrocarbon refrigerants such as R404A, propane, and butane sensors should be located near ground level

- With lighter than air gas e.g. ammonia, the sensor needs to be located above the equipment to be monitored on a bracket or high on a wall within 300 mm of, or on the ceiling provided there is no possibility of a thermal layer trapped under the ceiling preventing gas reaching the sensor. (NB. At very low temperatures, such as in a refrigerated cold store, ammonia gas becomes heavier than air).
- With similar density or miscible gases, such as CO or CO₂, sensors should be mounted about head high – say 1.5m.
- Sensors should be positioned a little way back from any high-pressure parts to allow gas clouds to form. Otherwise any leakage of gas is likely to pass by in a high-speed jet and not be detected by the sensor.
- Make sure that pits, stairwells and trenches are monitored since they may fill with stagnant pockets of gas.
- If a pressure relief vent pipe is fitted to the system, it may be a requirement to mount a sensor to monitor this vent pipe. It should be positioned about 2 m above the PRV to allow gas clouds to form.
- With racks or chillers pre-fitted with refrigerant sensors, these should be mounted so as to monitor the compressors or if extract ducts are fitted the airflow in the duct may be monitored.

Refrigerated Spaces

In refrigerated spaces sensors should be located in the return airflow to the evaporators on a sidewall, below head high preferred, or on the ceiling, not directly in front of an evaporator. In large rooms with multiple evaporators, sensors should be mounted on the central line between 2 adjacent evaporators, as turbulence will result in airflows mixing.

Chillers

In the case of small water or air-cooled enclosed chiller units mount the sensor so as to monitor airflow to the extract fans. With larger models also place a sensor inside the enclosure under or adjacent to the compressors

In the case of outdoor units:

- such as enclosed air-cooled chillers or the outdoor unit for VRV/VRF systems mount the sensor so as to monitor airflow to the extract fan. With large units also place a sensor inside the enclosure under or adjacent to the compressors

In the case of non-enclosed outdoor units

- If there is an enclosed machinery section then locate a sensor there.
- In the case of units with enclosed compressors, mount sensors in the enclosures
- Where you have protective or acoustic panels mount the sensor low down under the compressors where it is protected by the panels.
- With air-cooled chillers or air-cooled condensers with non-enclosed condenser sections it is difficult to effectively monitor leaks in the coil sections. With some designs it will be possible using an airflow sensor to monitor airflow to the start –up fans in the front or rear sections.
- If there is a possibility of refrigerant leaks into a duct or air-handling unit install a sensor to monitor the airflow.

Weatherproof sensors should be used for unprotected outdoor applications.

Air Conditioning – Direct systems VRV/VRF

EN378 states that at least one detector shall be installed in each occupied space being considered and the location of detectors shall be chosen in relation to the refrigerant and they shall be located where the refrigerant from the leak will collect. In this case refrigerants are heavier than air and detectors should have their sensors mounted low .e.g. at less than bed height in the case of an hotel or other similar Category Class A spaces. Ceiling or other voids if not sealed are part of the occupied space.



In a hotel room monitoring in ceiling voids would not strictly comply with EN378

Do's

- mount the in-room sensor at less than the normal heights of the occupants e.g in a hotel room this is less than bed height - between 200-500mm off the floor.
- away from draughts and heat sources like radiators etc.
- avoid sources of steam

Don'ts

- Do not mount sensors
 - under mirrors
 - at vanity units
 - in or near bathrooms

For further detailed Installation tips covering most installations and equipment types, chillers, air cooled chillers, etc. see our web site www.murco.ie.

4- ST-IAM Typical settings

Detection ranges and default settings vary with model and set up. For example, for R404A refrigerant the default range is 0-1000 ppm. The standard default settings with this model:

Relay 1	Low-level relay set at 500ppm, Normally Open, Automatic reset mode, 0 min delay
Relay 2	High-level relay set at 900ppm, Normally Open, Automatic reset mode, 0 min delay

For settings on a particular unit refer to the rating plate label which shows the gas, the calibration range, and the relay alarm set points: low and high.

5- ST-IAM - Operating Instructions

1- On powering up the ST-IAM, the green LED will light and the red and yellow LED's will flash for 2 second (software check). It will then sense for the presence of gas

2- In alarm condition:

- the green LED stays on
- low level alarm yellow LED will be on and relay 1 will operate
- high level alarm yellow and red LEDs will be on and relay 1 and 2 will operate
- the voltage and current output changes proportional to gas concentration

Table 1. Power Supply values at 12 V

Sensor type	Supply Voltage	Current (Amps)	Watts (Watts)	Supply Voltage	Current (Amps)	Watts RMS (Watts)
Semiconductor	12 V dc	0.23	2.76	12 V ac	0.3	3.6
Electrochemical	12 V dc	0.096	1.15	12 V ac	0.14	1.68
Catalytic	12 V dc	0.166	1.99	12 V ac	0.224	2.7
Infrared	12 V dc	0.2	2.4	12 V ac	0.23	2.76
Low Temperature Infrared	24 V dc Only	1.4	33.6			

6- ST-IAM – Test / Function Instructions

The ST-IAM Unit is calibrated in the factory and does not require to be calibrated on installation. After installation the units should be bump tested. Expose the sensors to test gas using a Murco ampoule (NH₃ or CO₂ etc) or test cylinder (appropriate to the installation) or, if not available, crack open the valve of a cigarette lighter (only for Semiconductor units) without igniting it and hold it over the vent holes on the upper right side of the Unit. The gas is heavier than air and should fall into the Unit. This will put the system into alarm. The LED's 1 + 2 will light showing the system is in alarm. The delay will prevent the siren sounding or relay switching for the preset delay, if delay is set.

With a bump test you can see the functions of the sensor - the LED's 1 + 2 will light, the relay and sounder will function, the output selected, say 0-10V- will show the gas level.

To test the relay function, check the delay is set at zero using the header as shown on diagram 1 and expose to gas as above.

After the gas has cleared the LED's 1 + 2 and relay will automatically reset.

Before testing the sensors on site the Unit must have been powered up for several hours and allowed to stabilize. (Output on 0-10V should approach 0V).

7- ST-IAM Sensor - Remote sensor head installation

If you do not wish to surface mount the ST-IAM or need to match room decor, we can supply a remote sensor with a decorative faceplate (standard: brushed stainless steel). The remote sensor is mounted in a UK electrical back box 44mm deep to which the vented face plate is fitted.

1. Remove the connector from the sensor PCB to feed the cable through the trunking.
2. Immediately refit the connector to the sensor board in the backbox. The ST-IAM and remote sensor must be kept together as they are calibrated together and are a matched pair.



Do not remove the sensor boards from a number of units at the same time in case they get mixed up. If doing so, label them, or, ensure you check the serial number on the main PCB and the remote sensor PCB are the same when re-installing.

- If construction / decoration is still going on, fit a standard plastic blanking plate immediately you install the sensor in the back box to avoid dust or damage to the in-room sensor. You can fit the SS vented plate when decoration is completed.
- Cleaning: the decorative face plate should be lightly dusted – it should not be sprayed with cleaning/polishing aerosols.**

8- ST-IAM Sensor - Annual Test

To comply with the requirements of EN378 and the F GAS regulation sensors must be tested annually. However local regulations may specify the nature and frequency of this test. If not the Murco recommended procedure should be followed. Contact us for details.

After exposure to a substantial gas leak, sensor should be checked and replaced if necessary.



Check local regulations on calibration or testing requirements.

9- ST-IAM –Troubleshooting

All ST-IAM units are checked and calibrated before shipment.

- If on first powering up the unit the green LED does not light, check your wiring. Also check the power supply and the voltage at the sensor connector CON 1.
- If you experience spurious alarms in the absence of a leak, contact us for instructions and support.

10- Connections to the ST-MON panel 8 or 16 Models.

- Connect the RS 485 at AB COM, or the 4-20mA output from the sensor transmitter to the STMON. The 0V connects to the C position (one for every 4 channels) and the 4-20mA output connects to positions 1 through 8 or 16 (16 shown)
- Connect a 12/30 VAC/DC power supply to the sensor transmitter ST-IAM 2 as per the sensor transmitter installation sheet.
- Connect 230V mains to the ST-MON at the LNE positions shown.
- The ST-MON will normally be set by us so that all low alarms on each channel are fed to Relay R2 and all high alarms will be fed to Relay R1.

These relays may be used to activate sirens, beacons, fans, switch off plant, as required by the particular installation. They are rated 1Amp at 24V.

Diagram 2

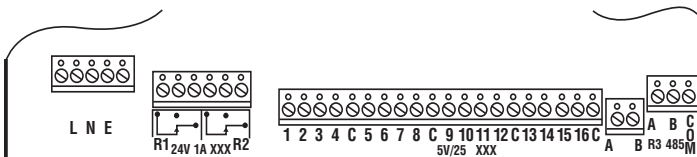

10.a Internal Connection Terminals

When first the sensors are connected and the system is powered the panel may go into alarm, (after any selected delay). The panel screen will flash red and a siren will operate. Pressing the siren mute button on the panel will silence the siren.

The system will stay in alarm until the sensors have normalised. This may take from minutes up to hours. When normalised press the ST-MON mute button again and the screen goes back to green and standby.

If during this normalisation period LED's 2 + 3 activate on any sensor indicating the relay has switched then the reset button on the sensor in alarm must be pushed after normalisation if the sensor relay is set to latched mode.

11-Communication Interface: RS485

RS485 interface Con 5 connector
Pin 1 =A, Pin 2= B, Pin 3 = Com (screen)

The sensors should be looped together. When connecting to the ST-MON panel the same terminals are connected to each other i.e. A-A, B-B, Com – Com. On the last sensor you fit a 120 ohm resistor across terminal positions AB so as to terminate the communications cable.

After you connect 31 sensors or cable is > 1000m to the ST-MON panel you then need to insert an IR12 signal repeater (booster) in the cable (See diagram 3). This will allow a further connection of up to 32 sensors; additional repeaters can be used for additional sensors.

Each sensor must have its address set up so the ST-MON panel can identify it (see table 2). A maximum of 99 addresses are possible. The sensor address is set by S2 and S3 on the ST-IAM 2, (as shown on Diagram 1). Power must be removed when setting addresses on the ST-IAM 2. We suggest that you note the physical location of each sensor so alarms can be easily located.

11.a Sensor Addresses

The mother board addresses are Hexadecimal and the ST-MON addresses Decimal

Table 2

Channel on ST-MON	S3	S2	Channel on ST-MON	S3	S2	Channel on ST-MON	S3	S2
1	0	1	34	2	2	67	4	3
2	0	2	35	2	3	68	4	4
3	0	4	36	2	4	69	4	5
4	0	4	37	2	5	70	4	6
5	0	5	38	2	6	71	4	7
6	0	6	39	2	7	72	4	8
7	0	7	40	2	8	73	4	9
8	0	8	41	2	9	74	4	A
9	0	9	42	2	A	75	4	B
10	0	A	43	2	B	76	4	C
11	0	B	44	2	C	77	4	D
12	0	C	45	2	D	78	4	E
13	0	D	46	2	E	79	4	F
14	0	E	47	2	F	80	5	0
15	0	F	48	3	0	81	5	1
16	1	0	49	3	1	82	5	2
17	1	1	50	3	2	83	5	3
18	1	2	51	3	3	84	5	4
19	1	3	52	3	4	85	5	5
20	1	4	53	3	5	86	5	6
21	1	5	54	3	6	87	5	7
22	1	6	55	3	7	88	5	8
23	1	7	56	3	8	89	5	9
24	1	8	57	3	9	90	5	A
25	1	9	58	3	A	91	5	B
26	1	A	59	3	B	92	5	C
27	1	B	60	3	C	93	5	D
28	1	C	61	3	D	94	5	E
29	1	D	62	3	E	95	5	F
30	1	E	63	3	F	96	6	0
31	1	F	64	4	0	97	6	1
32	2	0	65	4	1	98	6	2
33	2	1	66	4	2	99	6	3

12- Connections to repeater

If you wish to use more than 31 ST-IAM sensors in the system or cable is >1000m then you must install a repeater.

A typical repeater- IR12 is shown in diagram 3.

The detailed specification on the repeater is available for download on the suppliers Website reference:

<http://www.innotech.com.au/products/pdf/dsrprtr.pdf>

Diagram 3

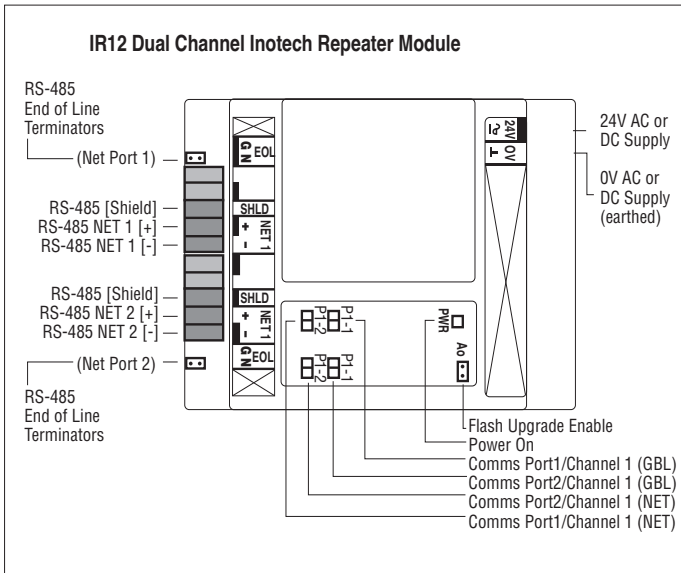

IR12 repeater connection are shown diagrammatically above.
 Due to baud rate of ST-MON panel only the Net channel can be used.

13- Agree Selectable functions with end users

You should agree these important functions with the customer so that the system will operate as he/she requires:

1. **Time Delay Response:** available on the relays to minimise any false alarm - set with jumpers. **The default delay is 0 minutes.** We suggest that you set to 15 minutes if installing during a construction phase as you may have VOCs (volatile organic compounds) fumes, paint etc in the rooms. They should be reset after such work is completed.
2. **Output:** Agree the output required, default settings are 4-20mA and 0-5V, 4-20mA, 0-10V, 0-5V, RS485
 2 Relays 1Amp at 24VDC or 120V AC.
3. **Connectivity:** Decide how the outputs are to be used. ST-IAM gas detectors can activate external systems such as fans or shut down and activate sirens, warning lights, activate dial out systems, or connect to most BMS, SCADA, or other control systems using one or more outputs as above.
4. **Reset:** Reset of the relays may either be automatic or latched requiring manual reset after the cause of a leak has been rectified.

14 – Mounting Instructions

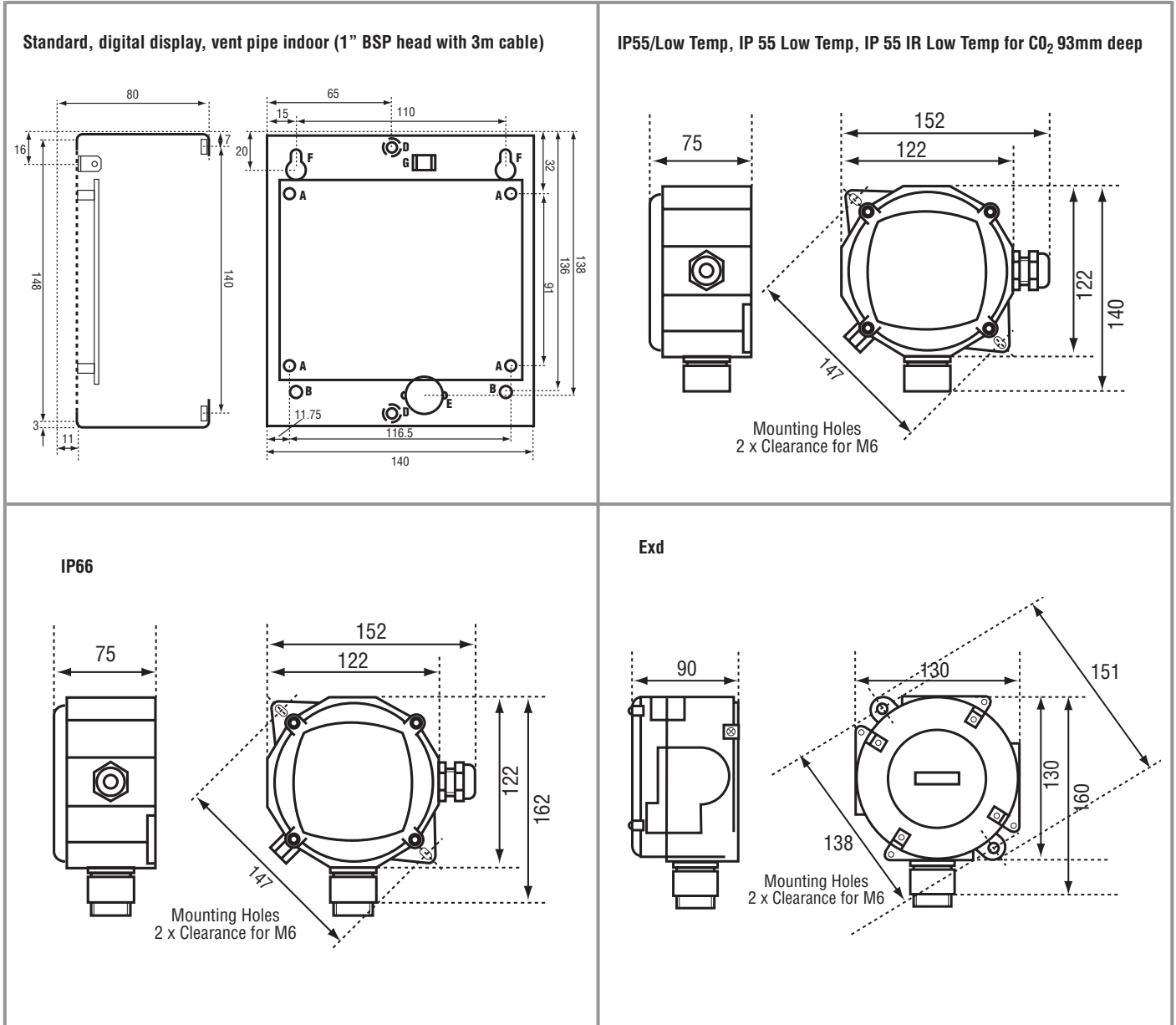

Exd with Digital Display

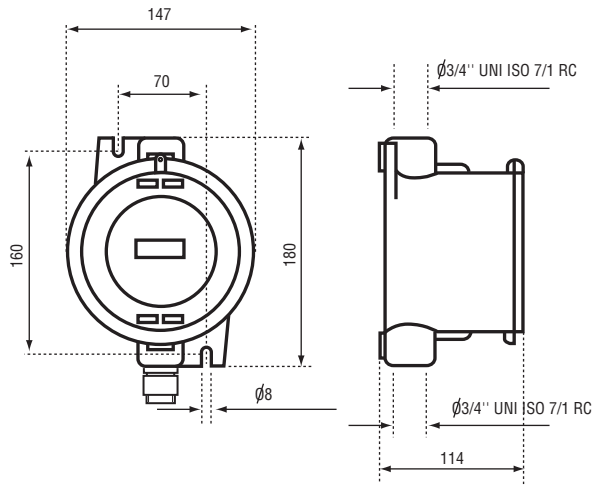

**Remote Exd Sensor Head, vent pipe outdoor (1" BSP head with 3m cable)
IP66 enclosure 5m remote IP65 Exd Sensor**

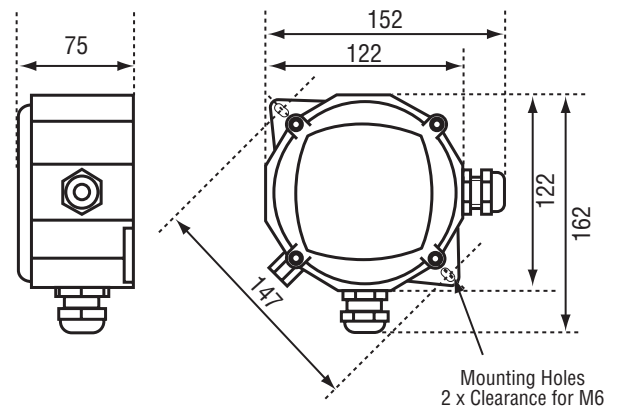

Airflow Duct Mount Outdoor

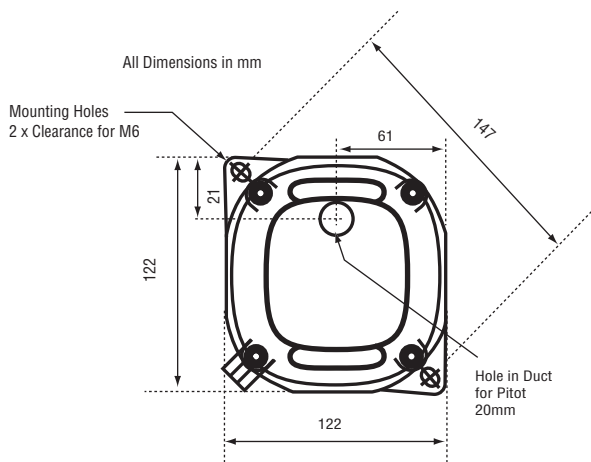

Pitot protrudes into duct 195mm

Airflow/Duct Mount Indoor Pitot protrudes into duct 195mm

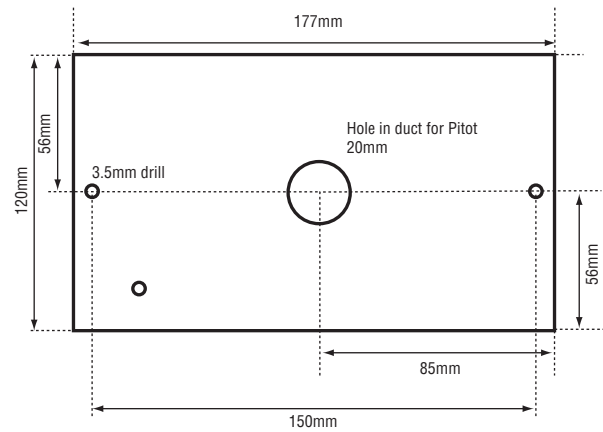

ST-Mon Controller

