



THORNE AND DERRICK UK – LEAK DETECTION  
 TEL: 0044 (0)191 490 1547 FAX: 0044 (0)191 477 5371  
 TEL: 0044 (0)117 977 4647 FAX: 0044 (0)117 477 5582  
 WWW.HEATTRACING.CO.UK  
 WWW.THORNEANDDERRICK.CO.UK  
 e-mail: northsales@thorneandderrick.co.uk

# sensazone

## installation guide



### 1 Introduction

**sensazone** is an intelligent PIR sensor which controls the water supply to the washroom via solenoid valves. It can control up to three solenoid valves for hot, cold and rain/grey water.

When movement is detected the sensor will send a pulse to the valve(s) and the LED will flash green once every three seconds. The valve(s) open allowing water to flow into the washroom feeding the terminal water fittings for either 15 or 30 minutes, as configured by the installer; after this period a second pulse will be sent to the valve(s) to close them. The timer is reset every time movement is detected.

If no movement is detected after 12 hours the **sensazone** will activate a hygiene cycle.



THORNE AND DERRICK UK – LEAK DETECTION  
 TEL: 0044 (0)191 490 1547 FAX: 0044 (0)191 477 5371  
 TEL: 0044 (0)117 977 4647 FAX: 0044 (0)117 477 5582  
 WWW.HEATTRACING.CO.UK  
 WWW.THORNEANDDERRICK.CO.UK  
 e-mail: northsales@thorneandderrick.co.uk

**Cistermiser**  
 water management at its best

## supplied parts

- 1 Solenoid valve
- 2 2 x 15 or 22mm compression fittings
- 3 Inlet filter
- 4 Fibre washer
- 5 Sensor assembly consisting of sensor unit and backplate
- 6 Mains power adaptor
- 7 2 x Rawlplugs
- 8 2 x #6 x 1 1/2" screws
- 9 4 x #4 x 1/2" screws
- 10 4 x sticky pads
- 11 Extension cable to mains power adaptor (1.25m)
- 12 Extension cable to solenoid valve (3m)

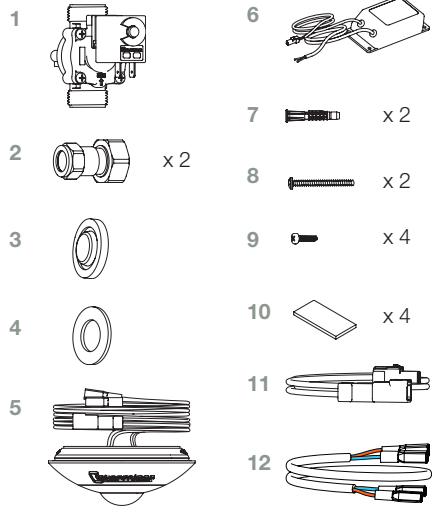

## 2 Sensor positioning

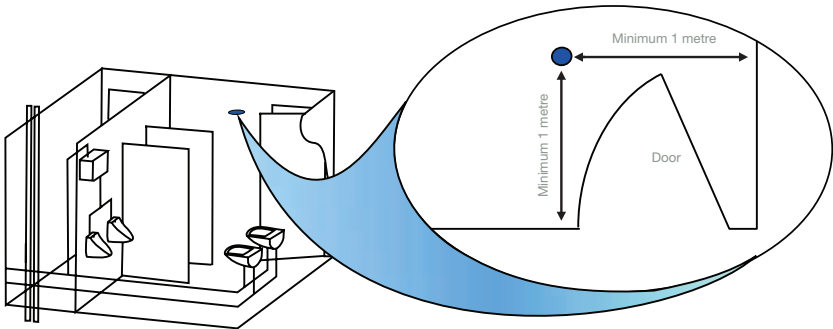

### 3 Installation schematic

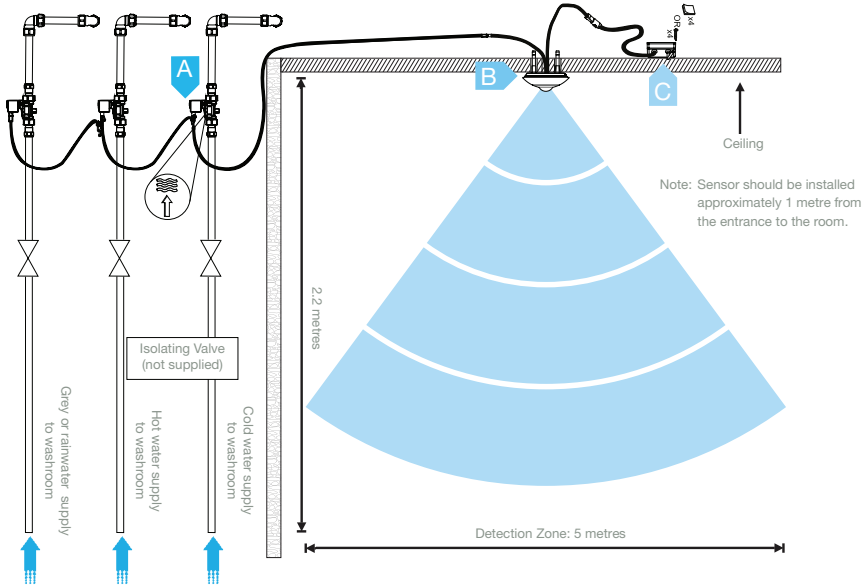

#### A Valve installation

Install valve onto the water supply leading into the washroom (hot, cold and rain/grey water) or as close as practically possible to the entry point to suit the pipe layout.

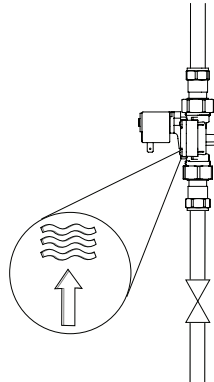

THORNE AND DERRICK UK – LEAK DETECTION  
 TEL: 0044 (0)191 490 1547      FAX: 0044 (0)191 477 5371  
 TEL: 0044 (0)117 977 4647      FAX: 0044 (0)117 477 5582  
 WWW.HEATTRACING.CO.UK  
 WWW.THORNEANDDERRICK.CO.UK  
 e-mail: northernsales@thorneandderrick.co.uk



## B Sensor installation

### false ceiling

1. Detach the backplate from the sensor unit.
2. Offer the backplate to the ceiling and mark position of holes.
3. Drill 6mm diameter holes and insert Rawlplugs.
4. Drill an additional hole of 10mm diameter between the two 6mm holes as shown below.



5. Screw the base plate to ceiling.
6. Feed the wire through the large (10mm) centre hole and secure the sensor unit to the base plate.
7. Twist sensor unit clockwise into backplate to lock into position.

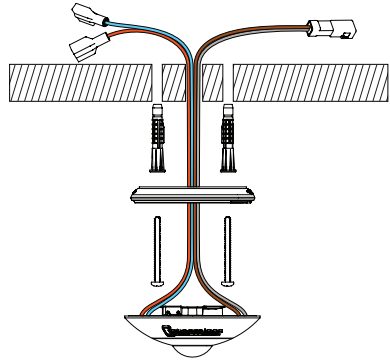

### solid ceiling

1. Detach the backplate from the sensor unit.
2. Offer the backplate to the ceiling and mark the position of holes. Pay particular attention to ensure that the 'wire exits' are correctly positioned for your installation.
3. Drill 6mm diameter holes and insert Rawlplugs.
4. Screw base plate to ceiling.
5. Ensure wire is fed through the 'wire exits' as displayed on the sensor. If the wire is required to go out of the same exit ensure that the wire is routed around the sensor as shown in the diagram below.
6. Secure sensor unit to base plate and twist clockwise to lock into position.

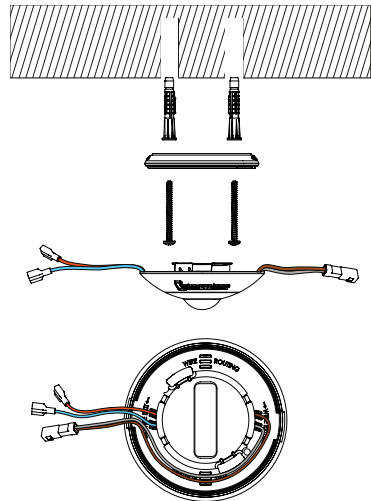

## C Mains power adaptor

Wire the mains adaptor into a 1A fused spur.

NOTE: this should not be further than 3 metres from the sensor unit.

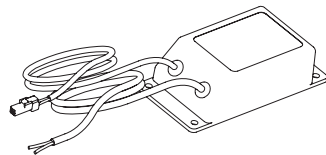

# 4 Final water and electrical connections

## single valve installations

Connect the spade connectors from the sensor unit to the solenoid tabs taking care to connect the wires according to the label. The solenoid cables are orange and turquoise. If these are not long enough they can be extended by up to 10 metres.

NOTE: Extension cables can be purchased from Cistermiser. Cables must have a minimum of 1.5mm<sup>2</sup> conductor size to connect to the solenoids.

## multiple valve installations

Multiple valves can be connected in parallel using the 'daisy chain' cable provided in the additional solenoid valve kit (AVK) as shown below. The AVK is available from Cistermiser or any major plumbing merchant. Ensure that like colours are connected. Use the 'piggy back' connector to loop 2 or 3 valves together as shown.

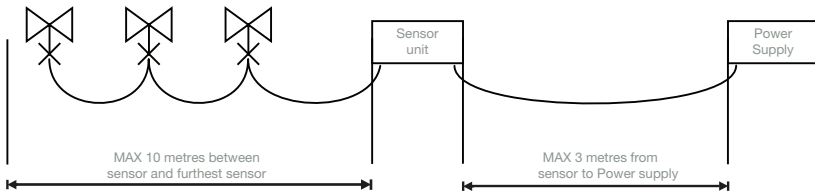
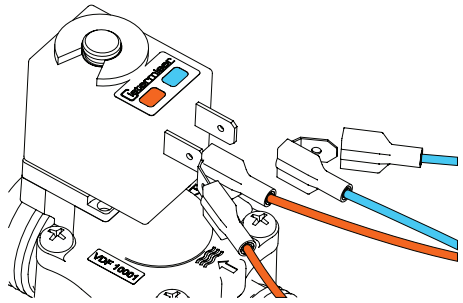

## power connection

Connect the power connector from the sensor unit to the mains adaptor. Colour conventions are brown for positive and grey for negative.

NOTE: Extension cables can be purchased from Cistermiser. Cables must have a minimum of 0.5mm<sup>2</sup> conductor size to connect to the mains power adaptor.

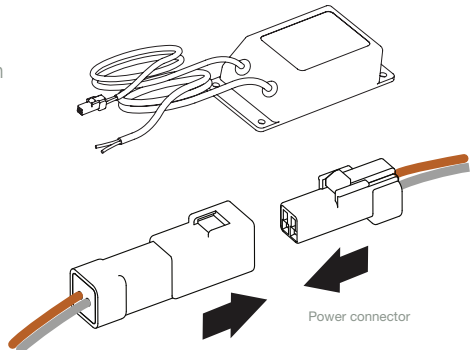

THORNE AND DERRICK UK – LEAK DETECTION  
TEL: 0044 (0)191 490 1547 FAX: 0044 (0)191 477 5371  
TEL: 0044 (0)117 977 4647 FAX: 0044 (0)117 477 5582  
WWW.HEATTRACING.CO.UK  
WWW.THORNEANDDERRICK.CO.UK  
e-mail: northernsales@thorneandderrick.co.uk



## 5 Testing and commissioning

### start up operation

When the **sensazone** is powered up the LED will be a constant amber for up to 15 seconds after which it will flash amber for 5 seconds. The water supply(ies) into the washroom will now be on for the default run-on time of 15 minutes. The default run-on time can be changed to 30 minutes. See the advanced setting guide at the end of this booklet.

### normal operation

When movement is detected, a pulse is sent to open the valve(s) and the LED will flash green once every three seconds for the duration of the run-on time. If movement is detected during the run-on time the timers are re-set and will keep the valve(s) open for a further 15 or 30 minutes from the time movement was last detected.

### testing

This can be done using the Infrared Configuration Unit (ICU) which is not supplied but is available from Cistermiser or any major plumbing merchant.

# 6 Usage advice and specification

Maximum working pressure:	6 bar
Minimum working pressure:	0.5 bar

## factory settings

Range:	~2.2m high x 5m diameter
Sensitivity setting:	Medium
Hygiene rinse:	On (30 minutes every 12 hours)
Run-on time:	15 minutes
Power requirements:	6V DC regulated from mains adaptor. (1A fused spur required)

## specification

Control classification:	Independent
Maximum load:	3 x 2W 0.33A (6VDC) EMC emissions tested at load
Rated temperature range:	0-40 deg C
Action classification:	Type 1.Y
Pollution classification:	Degree 1
Ingress protection:	IP55 or IP65 (with respect to room when smooth, non-porous ceiling tile used)
Solenoid extension cable:	3m length x 1.5mm <sup>2</sup> conductor size
Mains power extension cable:	1.25m length x 0.5mm <sup>2</sup> conductor size

# 7 Component dimensions

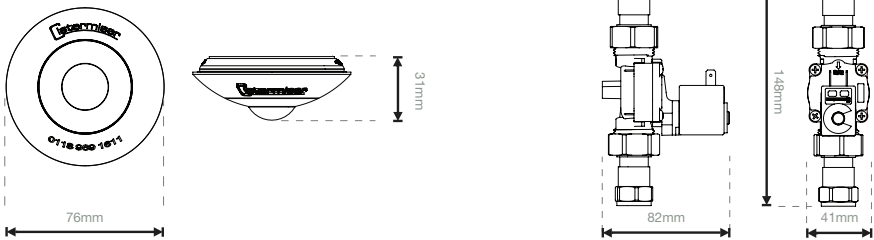

THORNE AND DERRICK UK – LEAK DETECTION  
TEL: 0044 (0)191 490 1547      FAX: 0044 (0)191 477 5371  
TEL: 0044 (0)117 977 4647      FAX: 0044 (0)117 477 5582  
WWW.HEATRACING.CO.UK  
WWW.THORNEANDDERRICK.CO.UK  
e-mail: northernsales@thorneandderrick.co.uk



# 8 Advance settings guide – manual configuration

The installer can adjust the run-on time as follows:

- 1 Disconnect power, wait for 5 seconds and reconnect.

NOTE: Sensor LED is constant amber for up to 15 seconds while checking ambient light level. If the ambient light level is not sufficient the sensor will automatically go into normal operation. To change settings increase light level in the room or purchase ICU.

- 2 When flashing **amber**



Cup hand over the sensor for 2 seconds only to enter into the run-on time configuration mode. LED will be constant **green**.



- 3 You are now in configuration mode

If a hand is not placed over the sensor, it will go into normal operation mode.

## Option 1: Run-on time adjustment (15 minutes)

- A Wait for **single green flashing** LED.



- B Cup your hand over the sensor for 2 seconds to select this option. The LED will be **constant green for 5 seconds**.



## Option 2: Run-on time adjustment (30 minutes)

- A Wait for **double green flashing** LED.



- B Cup your hand over the sensor for 2 seconds to select this option. The LED will be **constant green for 5 seconds**.



## Sequence of programme once option has been selected

- A Once your option has been chosen, the LED will be **constant green** for 5 seconds.



- B The LED will then be **constant amber** for 5 seconds.



- C The LED will then **flash amber**, giving the opportunity to re-enter configuration mode.













NOTE: If a hand is held over the sensor for more than 10 seconds the sensor will go into normal operation mode.

# 9 Infrared Configuration Unit (ICU) guide

NOTE: Not supplied but available from Cisterniser or any major plumbing merchant.

## button descriptions

-  Activates cleaning mode
-  Activates ICU configuration mode
-  Decreases setting
-  Increases setting
-  Checks the setting being altered
-  Saves changes and exits ICU configuration mode
-  Quits ICU configuration mode without saving changes
- 1**  Configures sensor range
- 4**  Configures run-on time
- 5**  12 hour hygiene cycle activation
- 9**  Resets to default factory settings

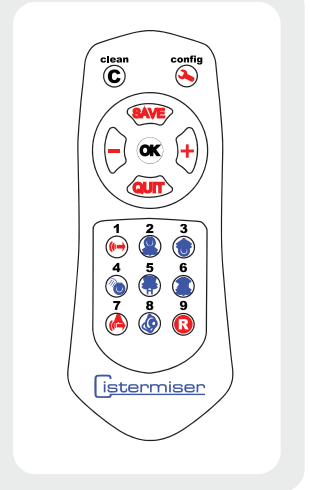

## activating walk test

When the **sensazone** is in normal operation, point the ICU at the **sensazone** and press **1** . The **sensazone** will flash green everytime it detects movement. This confirms that the unit is operating as it should be. After two minutes of no movement, the sensor returns to normal operation.

The product must be put into ICU configuration mode before any setting can be configured.

## activating clean mode

Point the ICU at the **sensazone** (in normal operation mode) and press the clean button . This will lock the solenoid valve(s) open or closed.

Constant green LED: valves locked open.

Constant red LED: valves locked closed.

Repeatedly pressing the clean mode will toggle between locked open and closed. If a delay of 4 seconds occurs after pressing the clean button,

the valve(s) remain locked in their state for 10 minutes after which the unit will default back to normal operation.

## entering configuration mode

Point the ICU towards the **sensazone** sensor and push the configuration  button. Activation is most effective when the configuration button is held down as the ICU is brought close to the sensor.

It can take up to 3 seconds for the product to sense the ICU. The **sensazone** will return to normal operation if there are no button presses for 30 seconds.



THORNE AND DERRICK UK – LEAK DETECTION  
TEL: 0044 (0)191 490 1547 FAX: 0044 (0)191 477 5371  
TEL: 0044 (0)117 977 4647 FAX: 0044 (0)117 477 5582  
WWW.HEATTRACING.CO.UK  
WWW.THORNEANDDERRICK.CO.UK  
e-mail: northern@thorneandderrick.co.uk



## configuring sensor sensitivity (range)

Enter into configuration mode. Point the ICU at the **sensazone** and press the **1** (↔): the sensor blinks green once.

Decrease or increase the sensor range by pressing the **⬅** and **➡** buttons respectively. The sensor blinks green every time **⬅** or **➡** is pressed and blinks red when the minimum or maximum value is reached.

Press **OK** button to verify the sensor sensitivity setting: the sensor displays the current setting by flashing green.

**Single flash:** minimum sensitivity setting.

**Double flash:** medium sensitivity setting.

**Triple flash:** maximum sensitivity setting.

Save setting and exit ICU configuration mode by pressing the **SAVE** button. The sensor will blink green for 1 second and then constant amber for 3 seconds.

To exit without saving press the **QUIT** button. The sensor will blink red for 1 second and then constant amber for 3 seconds.

## configuring occupancy (run-on) time

Enter into configuration mode. Point the ICU at the **sensazone** and press the **4** (⊙): the sensor blinks green once.

Decrease or increase the run-on time by pressing the **⬅** and **➡** buttons respectively. The sensor blinks green every time **⬅** or **➡** is pressed and blinks red when the minimum or maximum value is reached.

Press **OK** button to verify the sensor range setting: the sensor displays the current setting by flashing green.

**Single flash:** 15 minute run-on time set.

**Double flash:** 30 minute run-on time set.

Save setting and exit ICU configuration mode by pressing the **SAVE** button. The sensor will blink green for 1 second and then constant amber for 3 seconds.

To exit without saving press the **QUIT** button. The sensor will blink red for 1 second and then constant amber for 3 seconds.

## activating the 12 hour hygiene cycle

Enter into configuration mode. Point the ICU at the **sensazone** and press the **5** (⊙): the sensor blinks green once.

Pressing the **⬅** and **➡** buttons switches the hygiene cycle function on or off respectively. Press the **OK** button to verify the setting: the sensor displays the current setting by flashing green.

**Single flash:** hygiene cycle OFF

**Double flash:** hygiene cycle ON

Save setting and exit ICU configuration mode by pressing the **SAVE** button. The sensor will blink green for 1 second and then constant amber for 3 seconds.

To exit without saving press the **QUIT** button. The sensor will blink red for 1 second and then constant amber for 3 seconds.

## reset to factory settings

Enter into configuration mode. Point the ICU at the **sensazone** and press the **9** (R): the sensor blinks green once. This returns all settings to the default factory settings.

To save the setting and exit ICU configuration mode press the **SAVE** button. The sensor will blink green for 1 second and then constant amber for 3 seconds.

To exit without saving press the **QUIT** button. The sensor will blink red for 1 second and then constant amber for 3 seconds.

To activate the walk test and cleaning mode the **sensazone** should be in normal operating mode.

# 10 Frequently asked questions

## no water at outlets

LED not lit	Check electrical power supply to the sensor unit and all electrical connections to the valve.
Constant red LED	The unit has been left in the locked closed position and will remain in this position for 10 minutes after which it will go into normal operation. However the clean button on the ICU can be pressed to return to normal operation mode.
LED flashing green every 3 seconds	Ensure there is a water supply to valve. Ensure you have the minimum water pressure of 0.5 bar. Check the filter at the inlet side of the valve is clear of any debris. Check all electrical connections between the sensor and valves. Check to ensure the maximum cable runs between the sensor and valve have not been exceeded.

## water at outlets at all times

LED not lit	Check electrical power supply to the sensor and all electrical connections to the valve. If electrical power confirmed please contact Cistermiser for further advice.
Constant green LED	The unit has been left in the locked open position and will remain in this position for 10 minutes after which it will go into normal operation. However the clean button on the ICU can be pressed to return to normal operation mode.
Valves not opening or closing when they should	Check all electrical connections and ensure maximum cable runs have not been exceeded. If confirmed contact Cistermiser for further advice.

## other issues

Single or double red flash	Check wiring: if this is correct and the problem persists please contact Cistermiser.
Constant green LED	Indicates fault with wiring between mains supply, transformer and sensor.
When initially powered, sensor goes red and will not enter into configuration mode	Ambient light level may not be sufficient. Additional artificial light (a torch can be used) is required onto the sensor throughout configuration.
Can I install multiple <b>sensazones</b> in parallel?	NO. Connecting multiple <b>sensazones</b> in parallel to a solenoid will damage the sensor beyond repair.
What do I do if the sensor is not sensing occupancy in the washroom?	Conduct a walk test and if required adjust the sensor sensitivity setting as per section 9.



THORNE AND DERRICK UK – LEAK DETECTION  
TEL: 0044 (0)191 490 1547 FAX: 0044 (0)191 477 5371  
TEL: 0044 (0)117 977 4647 FAX: 0044 (0)117 477 5582  
WWW.HEATTRACING.CO.UK  
WWW.THORNEANDDERRICK.CO.UK  
e-mail: [northemsales@thorneandderrick.co.uk](mailto:northemsales@thorneandderrick.co.uk)





**Cisterniser**  
water management at its best



THORNE AND DERRICK UK – LEAK DETECTION  
TEL: 0044 (0)191 490 1547      FAX: 0044 (0)191 477 5371  
TEL: 0044 (0)117 977 4647      FAX: 0044 (0)117 477 5582  
WWW.HEATTRACING.CO.UK  
WWW.THORNEANDDERRICK.CO.UK  
e-mail: [northersales@thorneandderrick.co.uk](mailto:northersales@thorneandderrick.co.uk)