

Over-the-Side Immersion Heaters

Overview

Description

Over-the-Side Immersion Heaters are designed for installing in the top of a tank with the heated portion directly immersed along the side or at the bottom. This provides easy removal of the heater and ample working space inside the tank. These heaters are available with heating elements made of Copper, Steel, Stainless Steel, Cast Iron, INCOLOY®, Titanium, Fluoropolymer coated, and Quartz. A wide selection of kW ratings, shapes and mounting methods are available to suit many different types of applications.



Over-the-Side Immersion Heaters — Selection Guidelines

Configuration	Model	Sheath Material	Typ. Watt Density	Phase	See Note	
L-Shaped This type of heater puts the heat at the bottom of the tank. The vertical riser is unheated so lower liquid levels are acceptable. Many types of heating element materials are available along with various riser heights and element configurations. Legs are provided at the bottom of most heaters to prevent direct contact of the heating elements with the bottom of the tank.	KBLS	304SS	11	1	1	
	TLS, KTLS	304SS	40	1 or 3	1	
	GSL	316SS	20 and 40	1	2	
	GSL3, GSV3	316SS	20 and 40	3	2	
	CIT	Cast Iron	20	1	—	
	TLC, KTLC	Copper	40	1 or 3	1	
	TBL	INCOLOY®	20	1	—	
	TLI	INCOLOY®	40	1 or 3	1	
	KTLI	INCOLOY®	40	1	1	
	KBLC	Steel	11	1	1	
	TBL	Steel	20	1	—	
	TLO, KTLO	Steel	20	1 or 3	1	
	BLCK-MH	Steel	12 and 18	1 or 3	1	
	BLCS	Steel	12 and 18	1 or 3	—	
	GTFL, GXFL	Fluoropolymer	10	1	2	
	GTFNL3	Fluoropolymer	10	3	2	
	GTL	Titanium	20 and 40	1	2	
	GTL3, GTV3	Titanium	20 and 40	3	2	
	Side Mount/Top Mount This heater is placed on the side of the tank with mounting brackets for easy installation. A cold section is provided at the top of the heater for various levels of liquid in the tank (consult heater specification tables for the specific length of the cold section). Low profile side mounted heaters provide more working space in the heated tank.	PTHF	304SS	20	3	2
		CTSS	304SS	25 and 40	1	—
PTH		316SS	30	1	—	
GS		316SS	20 and 40	1	2	
GS3		316SS	20 and 40	1 or 3	2	
CTAC		Carp 20 SS	25 and 40	1	—	
CS		Ceramic-SiAlON	70	1 - 3	—	
CH-OTS		Copper	60	1	3	
CTC		Copper	25 and 40	1	—	
QM		Quartz	25	1	2	
QM3		Quartz	25	1 or 3	2	
GTF, GXF		Fluoropolymer	10	1	2	
GTF6, GTF9		Fluoropolymer	10	3	2	
TPR		Fluoropolymer	20	1	2	
TPF		Fluoropolymer	20	3	2	
PTHT		Titanium	20	1	—	
CTT		Titanium	44	1	—	
GT		Titanium	20 and 40	1	2	
Heat/Cool Exchangers Side mounted metal or fluoropolymer coils provide heat or cooling of tanks from remote mounted heating or cooling sources.		GT3	Titanium	20 and 40	1 or 3	2
		GHTF	Fluoropolymer	N/A	N/A	—
	GRS	316SS	N/A	N/A	—	
	GRT	Titanium	N/A	N/A	—	
	US	316SS	N/A	N/A	—	
	UT	Titanium	N/A	N/A	—	

1. Optional Integral Thermostat - requires wiring to remote relay (not included).
2. Integral Overheat Thermal Protection - requires wiring to remote relay (not included).
3. Integral Thermostat and Cutout.



More Information
is Available Online
on Tank Heating.

Bookmark Your Browser to

www.chromalox.com
and Select Manuals.

Over-the-Side Immersion Heaters

Application & Selection Guidelines

Applications

The large variation in heating element material and shapes of over-the-side immersion heaters offers a wide selection in the application of these units. Water, oils, solvents, plating baths, salts and acids are some of the many liquids and viscous materials commonly heated with immersion heaters. Over-the-side types permit portability, easy removal for cleaning of tanks and heaters and ample working area within the tank when installed.

Important — When selecting a tank heater design, the user should make sure the sheath material is suitable for the solution being heated at the maximum temperature expected, with proper safety factor.

Sheath Material — Selection Guidelines¹

Material Being Heated	Typical Sheath Material
Clean Water (pH6 to pH8)	Copper
Demineralized or De-ionized Water	Stainless Steel (passivated) INCOLOY® Fluoropolymer
Medium Weight Oil, Alkaline Cleaning (low concentration) Mild Soaking Cleaners	Steel
Mild to Medium Corrosive Solutions, Many Oxidizing Acids, Organic Chemicals, Mild Aqueous Solutions	Stainless Steel INCOLOY®
Chromic Acid (10%), Nitric Acid (to 65%) Salt Brine, Many Plating Solutions (i.e. Nickel, Silver, Zinc, Gold)	Titanium
Soft Metal Melting	Cast Iron
Molten Metal, High Corrosive	Ceramic
Most Acids, Plating Solutions, Pickling Solutions	Fluoropolymer Quartz ²

1. Consult Corrosion Guide in the Technical section for specific material recommendations.
2. Not for use in hydrofluoric acid and alkaline solutions.

OVER-THE-SIDE

L-Shaped Installation

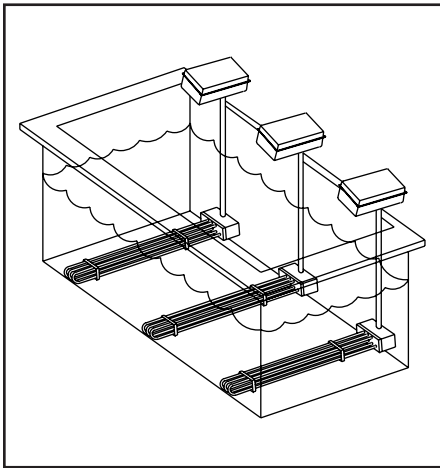

Side Mount Installation

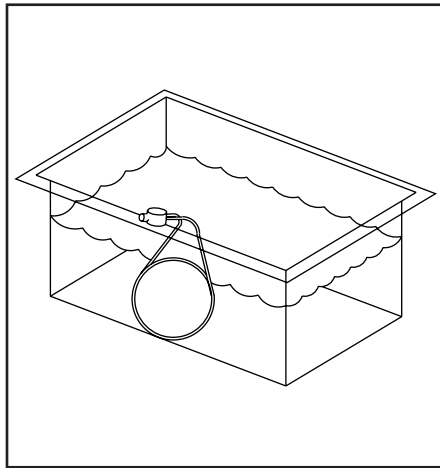

Deep Tank Installation

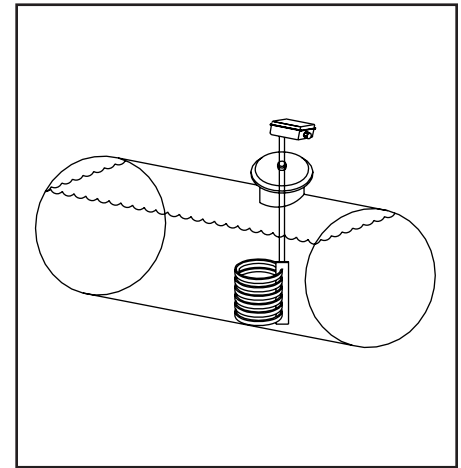

Over-the-Side Immersion Heaters — Selection Guidelines

Heater	Model	Page
L-Shaped Metal Sheath	TLC & KTLC	B-115
	TLO & KTLO	B-116
	TLS & KTLS	B-117
	TLI & KTLI	B-118
Side Mount Metal Tube	GS & GT	B-119
	GS3 & GT3	B-120
L-Shaped Metal Tube	GSL & GTL	B-121
	GSL3 & GTL3	B-122
	GSV3 & GTV3	B-123
Side Mount Quartz Tube	QM & QM3	B-124
Side Mount Metal Sheath	PTH & PTHT	B-125
	PTHF	B-126
	CT	B-127
Side Mount Fluoropolymer Coated	TPR & TPF	B-128
	GTF & GTFL	B-129
	GXF & GXFL	B-130
	GTF6 & GTF9	B-132
L-Shaped Fluoropolymer Coated	GTFL3	B-133

Heater	Model	Page
Drum Heater	KBLC & KBLS	B-134
Salt Bath Heater	TBL & TBL-A	B-135
Deep Tank Heater	BLCK-MH & BLCS	B-136
Portable Tank Heater	CH-OTS	B-137
Soft Metal Melting Heater	CIT	B-138
Ceramic Sheath	CS	B-139
Side Mount Heat Exchanger	GRT & GRS	B-141
	US & UT	B-143
	GHTF	B-144
Terminal Enclosure Dimensions		B-145
Optional Accessories		B-147

Over-the-Side Immersion Heaters

L-Shaped Metal Sheath Heaters



TLC, KTLC, TLO, KTLO,
TLS, KTLS, TLI, KTLI

- Copper, Steel, Stainless Steel, INCOLOY® Sheath Elements
- 20 and 40 W/In²
- 2 - 18 kW
- 120, 240 and 480 Volt, 1 & 3 Phase
- Moisture Resistant Terminal Enclosure
- Optional Integral Thermostat

Straight Elements — Dimensions (Inches)

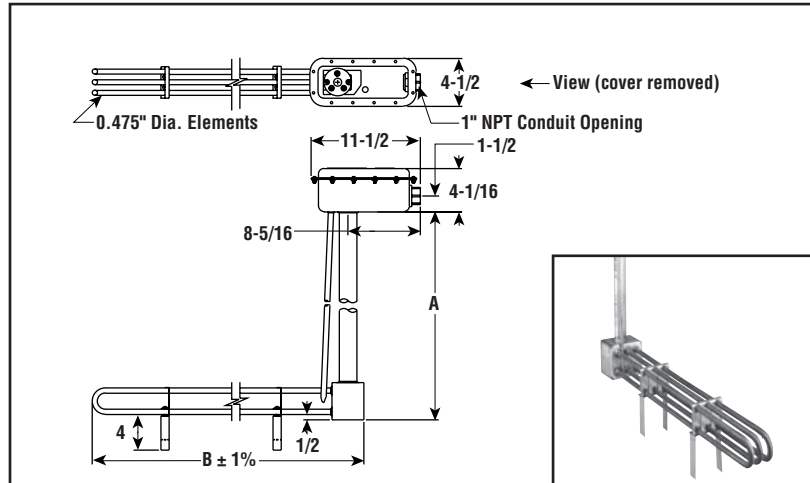

Circular Elements — Dimensions (Inches)

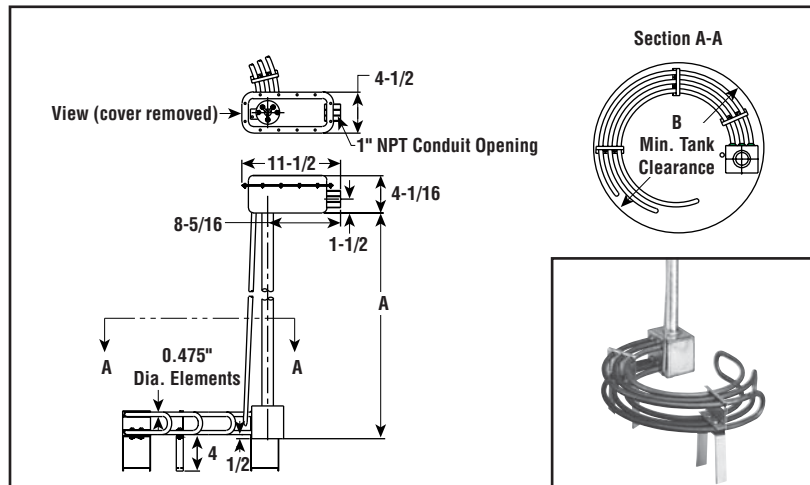

Description

Light weight, portable, easy to install L-shape construction, puts the heat at the bottom of the tank and the terminal enclosure at the top of the tank. Capacities, dimensions and heater sheaths fit a wide range of heating applications. Easy to install and remove for cleaning with straight or circular element designs to fit many tank configurations.

Features

- Copper Sheath and Riser (40 W/In²)
- Steel Sheath and Riser (20 W/In²)
- Stainless Steel Sheath and Riser (40 W/In²)
- INCOLOY® Sheath and Stainless Steel Riser (40 W/In²)
- 36 and 48" Riser Heights
- Moisture Resistant Terminal Enclosure
- Thermowell (standard on S and AS heaters)
- 4" Sludge Legs (standard on S and AS heaters). Increases A dimension 3-1/2". Keeps heated section off bottom of tank.

Optional Features

- Integral Thermostat Kit DPST "AR" type rated 30 Amp at 120 - 277V (field installed)
 - 60 - 250°F (AR-219 Kit, PCN 277819)
 - 200 - 550°F (AR-519 Kit, PCN 277827)¹
 - 0 - 100°F (AR-115 Kit, PCN 277835)
- Factory Installed Thermostat (specify range above)
- Explosion Resistant Terminal Enclosure (GSA/NRTL Certified)
- Longer Riser and Sludge Leg Heights
- INCOLOY® Riser
- Process and Overtemperature Protection Thermocouples
- Increase Number of Elements (horizontally and/or vertically) for larger kW ratings
- Lower Watt Densities for heating Viscous Materials
- Manhole Construction for Covered Tanks

Note —

1. Not UL Listed or CSA Certified with 200 - 550°F Thermostat Kit